



Xenon Lamps for SONY Digital Cinema Projector

# DXL-30SRX

### Technical Data

|                   |               |        |       |
|-------------------|---------------|--------|-------|
| Input Power       | W             | -      | 3000  |
| Voltage           | V             | -      | 30    |
| Current           | A             | -      | -     |
| Lamp Length       | mm            | a      | 295   |
| LCL               | mm            | b      | 128   |
| Cold Arc Gap      | mm            | c      | 4.5   |
| Cathode           | Base Diameter | mm (Φ) | d     |
|                   | Pin Diameter  | mm (Φ) | e     |
|                   | Pin Length    | mm     | f     |
| Anode             | Base Diameter | mm (Φ) | g     |
|                   | Pin Diameter  | mm (Φ) | h     |
|                   | Pin Length    | mm     | i     |
| Bulb diameter     | mm (Φ)        | j      | 53    |
| Cable length      | mm            | k      | 215   |
| Crimping terminal | mm            | l      | 22-10 |

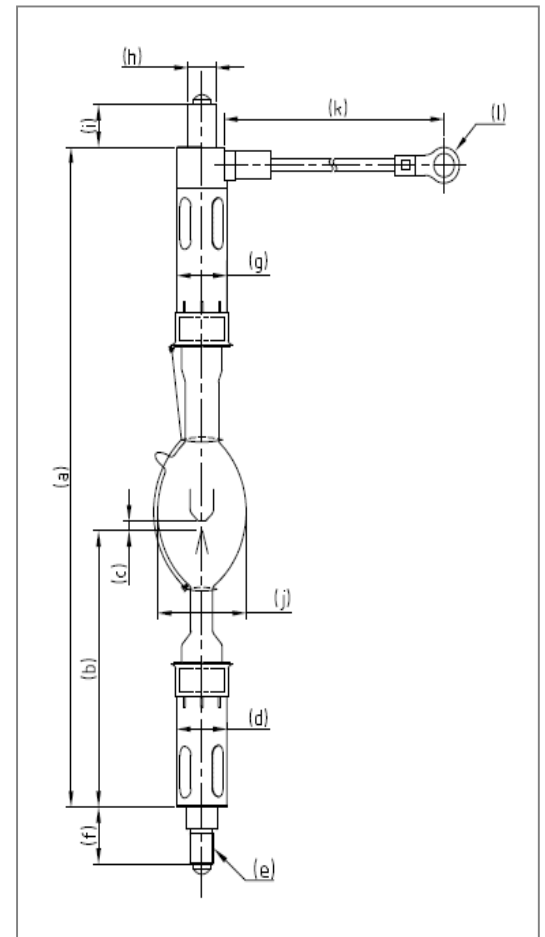

### Warranty Hours

|           |      |
|-----------|------|
| DXL-30SRX | 1000 |
|-----------|------|

### Cross Reference

| Lamp Type | Projector Model      |
|-----------|----------------------|
| DXL-30SRX | SRX-R220<br>SRX-R320 |