

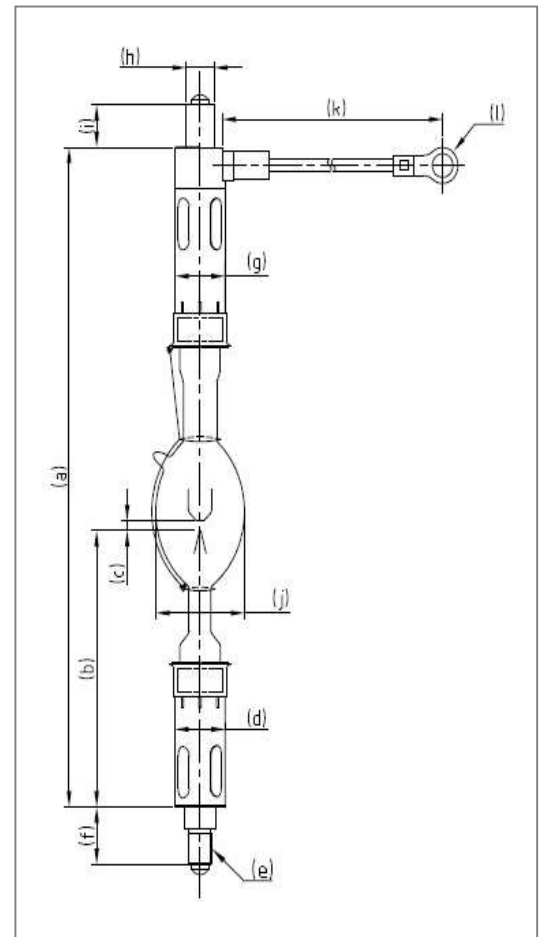

# DXL-20SRX

## Technical Data

Input Power	W	-	2000
Voltage	V	-	25.5
Current	A	-	-
Lamp Length	mm	a	295
LCL	mm	b	128
Cold Arc Gap	mm	c	4
Cathode	Base Diameter	mm (Φ)	d
	Pin Diameter	mm (Φ)	e
	Pin Length	mm	f
Anode	Base Diameter	mm (Φ)	g
	Pin Diameter	mm (Φ)	h
	Pin Length	mm	i
Bulb diameter	mm (Φ)	j	53
Cable length	mm	k	215
Crimping terminal	mm	l	14-10



## Warranty Hours

DXL-20SRX	2400 (3000*)
-----------	--------------

\*The mentioned warranty hours in the brackets is for " ignition & burst ".

## Cross Reference

Lamp Type	Projector Model
DXL-20SRX	SRX-R220 SRX-R320