

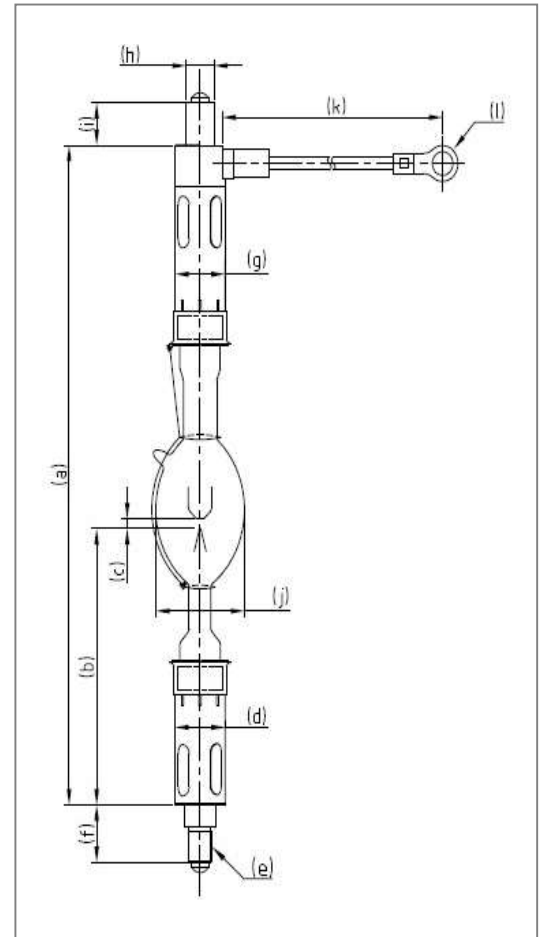

DXL-30SRX

Technical Data

Input Power	W	-	3000
Voltage	V	-	30
Current	A	-	-
Lamp Length	mm	a	295
LCL	mm	b	128
Cold Arc Gap	mm	c	4.5
Cathode	Base Diameter	mm (Φ)	d
	Pin Diameter	mm (Φ)	e
	Pin Length	mm	f
Anode	Base Diameter	mm (Φ)	g
	Pin Diameter	mm (Φ)	h
	Pin Length	mm	i
Bulb diameter	mm (Φ)	j	53
Cable length	mm	k	215
Crimping terminal	mm	l	22-10



Warranty Hours

DXL-30SRX	1000
-----------	------

Cross Reference

Lamp Type	Projector Model
-----------	-----------------

DXL-30SRX	SRX-R220 SRX-R320
-----------	----------------------