



Xenon Lamps for Sharp NEC Display Solutions Digital Cinema Projector

DXL-30SN2/L

Technical Data

Input Power	W	-	3000	
Voltage	V	-	30.5	
Current	A	-	98	
Lamp Length	mm	a	306	
LCL	mm	b	144	
Cold Arc Gap	mm	c	5.4	
Cathode	Base Diameter	mm (Φ)	d	27
	Pin Diameter	mm (Φ)	e	20
	Pin Length	mm	f	14
Anode	Base Diameter	mm (Φ)	g	30
	Pin Diameter	mm (Φ)	h	14
	Pin Length	mm	i	9
Bulb diameter	mm (Φ)	j	60	
Cable length	mm	k	160	
Crimping terminal	mm	l	22-10	

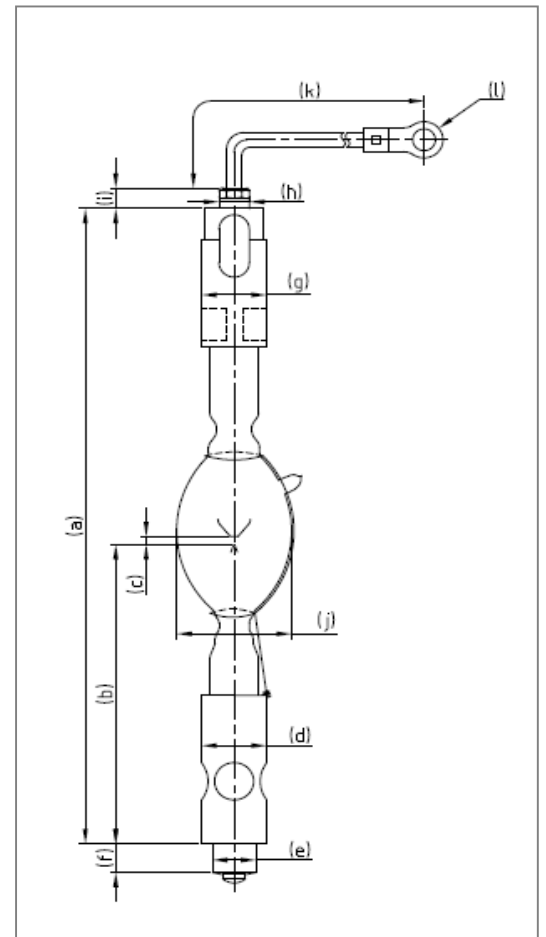

Warranty Hours

DXL-30SN2/L

1800

Cross Reference

Lamp Type

Projector Model

DXL-30SN2/L

NC1600C
NC2000C