



Xenon Lamps for Sharp NEC Display Solutions Digital Cinema Projector

# DXL-31SN2

### Technical Data

Input Power	W	-	3000
Voltage	V	-	28.5
Current	A	-	105
Lamp Length	mm	a	423
LCL	mm	b	171.5
Cold Arc Gap	mm	c	5.4
Cathode	Base Diameter	mm (Φ)	d
	Pin Diameter	mm (Φ)	e
	Pin Length	mm	f
Anode	Base Diameter	mm (Φ)	g
	Pin Diameter	mm (Φ)	h
	Pin Length	mm	i
Bulb diameter	mm (Φ)	j	60
Cable length	mm	k	(220)
Crimping terminal	mm	l	22-10

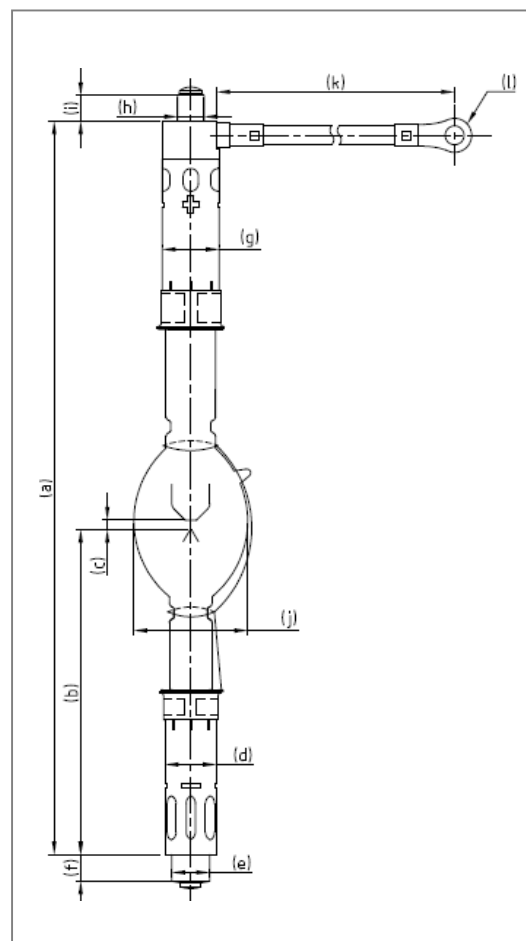

### Warranty Hours

DXL-31SN2

1200

### Cross Reference

Lamp Type

Projector Model

DXL-31SN2

NC2500S  
NC3200S  
NC3240S