



Xenon Lamps for Sharp NEC Display Solutions Digital Cinema Projector

DXL-41SN/L

Technical Data

Input Power	W	-	4000
Voltage	V	-	33
Current	A	-	120
Lamp Length	mm	a	387
LCL	mm	b	171.5
Cold Arc Gap	mm	c	5.3
Cathode	Base Diameter	mm (Φ)	d
	Pin Diameter	mm (Φ)	e
	Pin Length	mm	f
Anode	Base Diameter	mm (Φ)	g
	Pin Diameter	mm (Φ)	h
	Pin Length	mm	i
Bulb diameter	mm (Φ)	j	60
Cable length	mm	k	220
Crimping terminal	mm	l	22-10

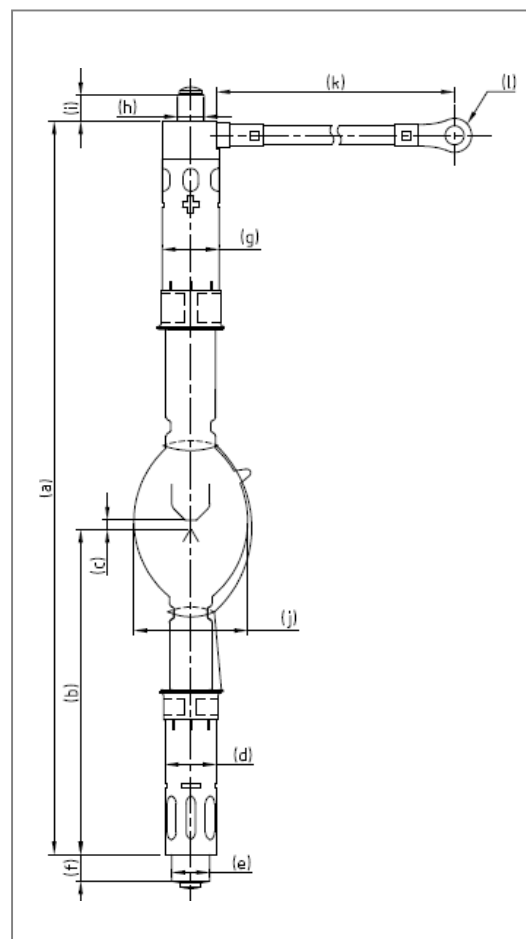

Warranty Hours

DXL-41SN/L

850

Cross Reference

Lamp Type

Projector Model

DXL-41SN/L

NC2500S
NC3200S
NC3240S