



Xenon Lamps for Sharp NEC Display Solutions Digital Cinema Projector

DXL-60SN/LU

Technical Data

| | | | | |
|-------------------|---------------|--------|-------|----|
| Input Power | W | - | 6000 | |
| Voltage | V | - | 39 | |
| Current | A | - | 155 | |
| Lamp Length | mm | a | 387 | |
| LCL | mm | b | 171.5 | |
| Cold Arc Gap | mm | c | 8 | |
| Cathode | Base Diameter | mm (Φ) | d | 30 |
| | Pin Diameter | mm (Φ) | e | 14 |
| | Pin Length | mm | f | 18 |
| Anode | Base Diameter | mm (Φ) | g | 30 |
| | Pin Diameter | mm (Φ) | h | 20 |
| | Pin Length | mm | i | 18 |
| Bulb diameter | mm (Φ) | j | 80 | |
| Cable length | mm | k | 220 | |
| Crimping terminal | mm | l | 22-10 | |

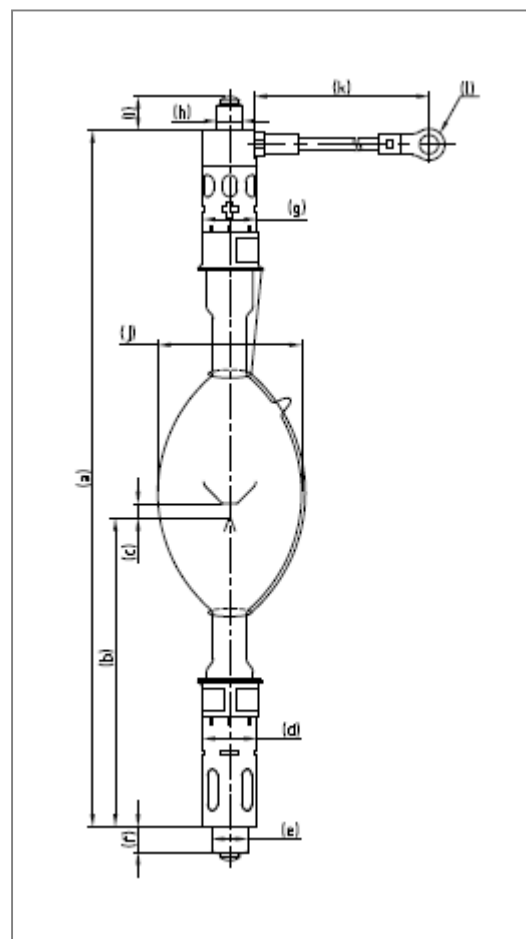

Warranty Hours

DXL-60SN/LU

1000

Cross Reference

Lamp Type

Projector Model

DXL-60SN/LU

NC2500S(*)
NC3200S(*)
NC3240S(*)

*Combination of 7kw lamp power supply unit