

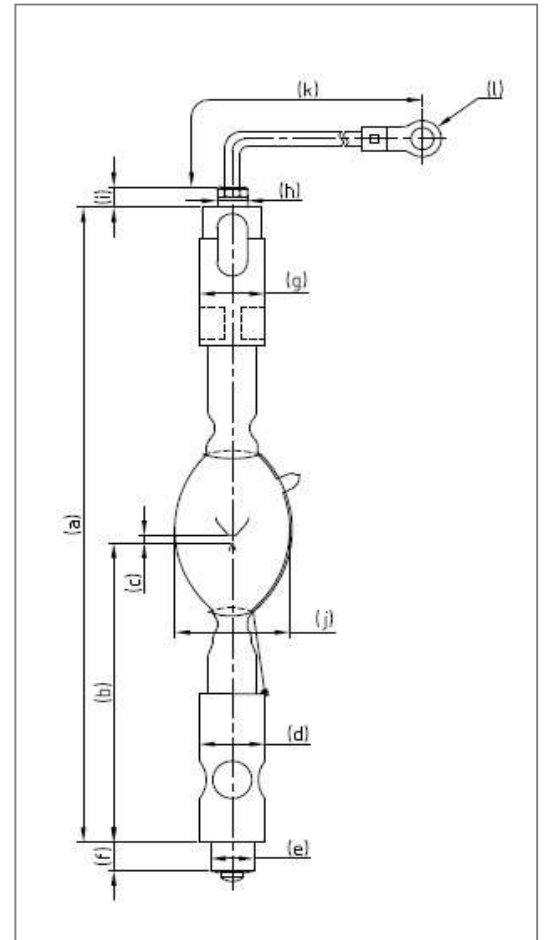

DXL-15SN

Technical Data

Input Power	W	-	1500
Voltage	V	-	22
Current	A	-	68
Lamp Length	mm	a	306
LCL	mm	b	144
Cold Arc Gap	mm	c	3.5
Cathode	Base Diameter	mm (Φ)	d
	Pin Diameter	mm (Φ)	e
	Pin Length	mm	f
Anode	Base Diameter	mm (Φ)	g
	Pin Diameter	mm (Φ)	h
	Pin Length	mm	i
Bulb diameter	mm (Φ)	j	42
Cable length	mm	k	(160)
Crimping terminal	mm	l	22-10



Warranty Hours

DXL-15SN	3000
----------	------

Cross Reference

Lamp Type	Projector Model
-----------	-----------------

DXL-15SN	NC1200C NC2000C
----------	--------------------