

SpectraTec™ X

Multi-Wavelength Laser Source

**BLUE SKY
RESEARCH**

- Up to four individual laser wavelengths
- One single mode PM fiber output
- Ultra-stable power output
- Compact : 165mm x 125mm x 34mm
- Integrated control and drive electronics



The SpectraTec™ X, multi-wavelength laser module is a highly integrated system comprised of up to four lasers, individual driving, control and stability electronics, a fiber optic wavelength combiner, temperature controllers (TECs), and a single mode fiber optic pigtail. In addition, complete control and interrogation of the module status is available via the 37-pin interface connector. A Fiber Feedback Collimator (FFC) provides precision beam shaping or beam focusing, and real time power feedback to the control circuits. Power Stability is <0.5% under normal operating conditions.

This system leverages our extensive experience in precision fiber coupling of laser diodes providing the highest degree of fiber coupling stability. This results in systems that have near perfect laser beam co-linearity and beam stability enabling the design of instruments and systems with high stability and reliability. A key feature of the SpectraTec™ X source is that each laser can be activated individually, all lasers can be on at the same time while also maintaining true APC power stabilization, and the intensity of each laser can be adjusted to best suit your application.

Custom OEM configurations are available and include wavelength options ranging from 405 to 980nm w/polarization maintaining fiber, various power levels, OEM specific collimation or relay optics, multimode lasers, multimode fibers, and various cabling and fiber connector types. We can co-engineer custom interfaces (with your engineering team) to match your system control, monitoring and operational requirements.

WAVELENGTHS

405
450
473
488
520
532
633
638
658
705
740
785
808
830
850
905
980

Contact Information:

Blue Sky Research * 510 Alder Drive * Milpitas, CA 95035 * (408)941-6068* Fax (408)941-0406
www.blueskyresearch.com* email: Sales@blueskyresearch.com
SpectraTec™ X Rev 06132017

SpectraTec™ X

Polarized Multi-Laser Source

SpectraTec™ X Multi-Channel Wavelengths

The SpectraTec™ X provides a stable, rugged, laser-based illumination source which never needs laser re-alignment in your system or instrument. The single mode, polarization maintaining output fiber combines up to four lasers. Standard configurations are available, please contact us to discuss your particular requirements. Multimode fiber outputs are available upon request. An example of a popular R-G-B-V laser system configuration is: 638nm + 532nm + 488nm + 405nm

Optical Specifications	Popular Wavelengths								
Wavelengths*	nm	405	450	488	520	532	638	658	785
Laser Output Power (Max)	mW	25	20	25	25	25	50	50	40
Fiber output mode field dia	µm	3.0	4.0	3.5	3.5	3.5	4.2	4.2	4.5
FFC module output beam dia	mm	1.7	1.7	1.7	1.8	1.8	1.9	1.9	1.9
Divergence (Far Field)	mRad	0.45	0.45	0.45	0.4	0.4	0.35	0.35	0.35

* A variety of single mode laser wavelengths and power levels are available for combining; some of the more common wavelengths include; 405, 450, 473, 488, 520, 532, 632, 638, 658, 785, 808, 830, 850, 905 and 980. For single mode operation the combined set of lasers must be between 405nm and 660nm or 660nm and 980nm. Custom OEM configurations are available.

General Product Specifications: (PM fiber with FFC, fiber feedback collimator)

Optical Parameter	Units	Specification			Conditions* All Laser Wavelengths
		Min.	Typ.	Max	
Power stability (1 hours)	%			0.5	All wavelengths, 1 hrs, ΔT +/- 3°
Power stability (24 hours)	%			≤2.0	All wavelengths, 24 hrs
Power stability (ΔT)	%			2.5	All wavelengths, ΔT= 10° - 40° @1°C/min
Laser Noise, RMS	% RMS			<0.5	10Hz – 2MHz BW, at 50-100% power
Laser Noise Pk-Pk	%			1.25	10Hz – 2MHz BW, @ 50-100% power level
Polarization Ratio	dB	20	25		Vertical, all wavelengths
Beam Aspect Ratio		0.9	1.0	1.1	Over beam path, 1/e ²
Pointing Angle	mRad		1	3	Referenced to FFC faceplate
Beam Co-alignment	µRad			300	At 1m distance
Laser Beam Diameter	mm	1.6	1.7	2.1	Exit - 20cm from collimator, 1/e ² value
Laser Beam Divergence	mrاد	0.3	0.45	0.75	Far Field, wavelength dependent
Laser Shutdown Time	µs		20	50	
M2				1.1	Calculated, Far Field, any channel
X-Talk	%		1		Target Laser power @ 50-100% Other Laser switched on/off @ 100% power
RoHS Compliant		Yes			All parts, assemblies and packaging
CDRH Classification		IIIb			
ESD Rating		Level 4			

* all data at constant temperature unless specified otherwise

Contact Information:

Blue Sky Research * 510 Alder Drive * Milpitas, CA 95035 * (408)941-6068* Fax (408)941-0406

www.blueskyresearch.com* email: Sales@blueskyresearch.com

SpectraTec™ X Rev 06132017

SpectraTec™ X

Polarized Multi-Laser Source

Absolute Maximum Ratings

Parameter	Units	Specifications		Conditions
		Min	Max	
Operating Temperature	°C	10	40	Non-Condensing
Storage Temperature	°C	-10	75	Non-Condensing
Storage Humidity	%	10	90	Non-Condensing

General Electrical Specifications:

Electrical Specifications	Units	Specifications	
Operating Voltage	V	5V ± 0.5, 8V ± 0.5	
Operating Current	A	3A max for 5V, 8V varies w/lasers. Typically < 0.5A	
		High-Speed modulation ACC mode only	Standard modulation lasers APC or ACC mode
Analog Modulation Freq		1MHz	10KHz
Rise Time	nS	250	10,000
Fall Time	nS	100	5,000
Dynamic Extinction Ratio	dB	>25	>25

General Mechanical Specifications

Mechanical Parameter	Units	Specification	Comments
Housing		Aluminum	
Dimensions	mm	165 x 125 x 34	L x W x H, see drawing for details
FFC Housing		Aluminum	
FFC Dimensions	mm	105 x 40 x 26	L x W x H, see drawing for details
Static beam location (V)	mm	9	referenced to collimator base
Static beam location (H)	mm	27.5	referenced to mounting hole center
Fiber Type		Nufern HPS460 PMF or equivalent	Varies by wavelength plan
Output Fiber Cable		3mm buffer or armored	50 – 100cm lengths available
Interface connector		37 pin D-Sub	On SpectraTec housing

Contact Information:

Blue Sky Research * 510 Alder Drive * Milpitas, CA 95035 * (408)941-6068* Fax (408)941-0406

www.blueskyresearch.com* email: Sales@blueskyresearch.com

SpectraTec X Rev A 06132017

SpectraTec™ X

Polarized Multi-Laser Source

Electrical Interface

37-pin D-sub Connector	Name	Direction	Comment
J1-1	GND	Power Input	TEC Gnd
J1-2	GND	Power Input	TEC Gnd
J1-3	GND	Power input	TEC Gnd
J2-4	GND	Power Input	Tec Gnd
J1-5	Laser 1 - Status TEC OK	Digital Output	Output Hi when TEC is in Temp range
J1-6	Laser 3 - Status TEC OK	Digital Output	Output Hi when TEC is in Temp Range
J1-7	GND	Power Input	System Gnd
J1-8	Laser 4 Enable	Digital input	Active HI
J1-9	Laser 4 - PD Monitor	Analog Output	Photodiode Monitor Voltage
J1-10	Laser 3 - Power Adjust	Analog Input	Output Power Adjustment/Modulation
J1-11	Laser 3 -LD Monitor	Analog Output	Laser Drive Current Monitor Voltage
J1-12	GND	Power Input	System Gnd
J1-13	Laser 2 - Enable	Digital Input	Active Hi
J1-14	Laser 2 - PD Monitor	Analog Output	Photodiode Monitor Voltage
J1-15	Laser 1 - Power Adjust	Analog Input	Output Power Adjustment/Modulation
J1-16	Laser 1 - LD Monitor	Analog Output	Laser Drive Current Monitor Voltage
J1-17	GND	Power Input	System Gnd
J1-18	GND	Power Input	System Gnd
J1-19	GND	Power input	System Gnd
J1-20	+5V	Power Input	Power for TECs
J1-21	+5V	Power Input	Power for TECs
J1-22	+5V	Power Input	Power for TECs
J1-23	+5V	Power input	Power for TECs
J1-24	Laser 2 - Status TEC OK	Digital Output	Output Hi when TEC is in Temp Range
J1-25	Laser 4 - Status TEC OK	Digital output	Output Hi when TEC is in Temp Range
J1-26	Laser 4 - Power Adjust	Analog Input	Output Power Adjustment/Modulation
J1-27	Laser 4 - LD Monitor	Analog Output	Laser Drive Current Monitor Voltage
J1-28	GND	Power Input	System Gnd
J1-29	Laser 3 - Enable	Digital Input	Active Hi
J1-30	Laser 3 - PD Monitor	Analog Output	Photodiode Monitor Voltage
J1-31	Laser 2 - Power Adjust	Analog Input	Output Power Adjustment/Modulation
J1-32	Laser 2 - LD Monitor	Analog Output	Laser Drive Current Voltage
J1-33	GND	Power Input	System Gnd
J1-34	Laser 1 - Enable	Analog Input	Active Hi
J1-35	Laser 1 - Monitor PD	Analog Output	Photodiode Monitor Voltage
J1-36	+8.0 V	Power Input	Power for System
J1-37	+8.0V	Power Input	Power for System

The SpectraTec™ X module has a 37 pin D-sub male connector. The module is provided with a 50cm cable terminated in a 37 pin D-Sub Female connector on both ends providing pin functions in the table above. Custom OEM interface options can be developed.

Contact Information:

Blue Sky Research * 510 Alder Drive * Milpitas, CA 95035 * (408)941-6068* Fax (408)941-0406

www.blueskyresearch.com* email: Sales@blueskyresearch.com

SpectraTec™ X

Polarized Multi-Laser Source

Mechanical Drawing

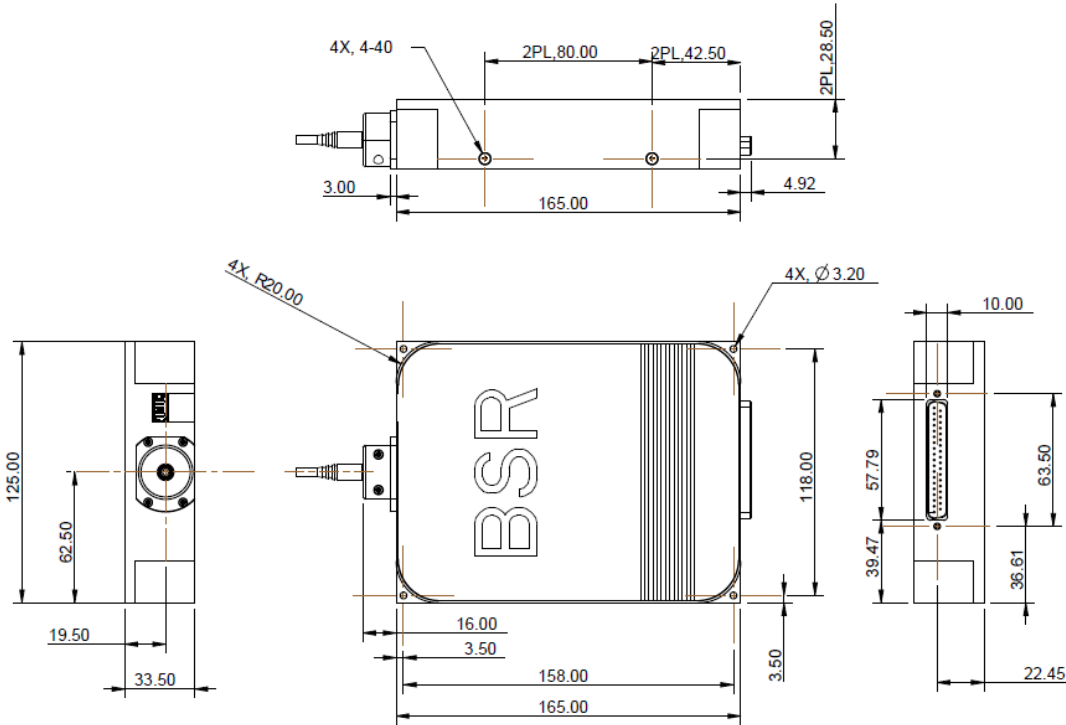

FFC Housing

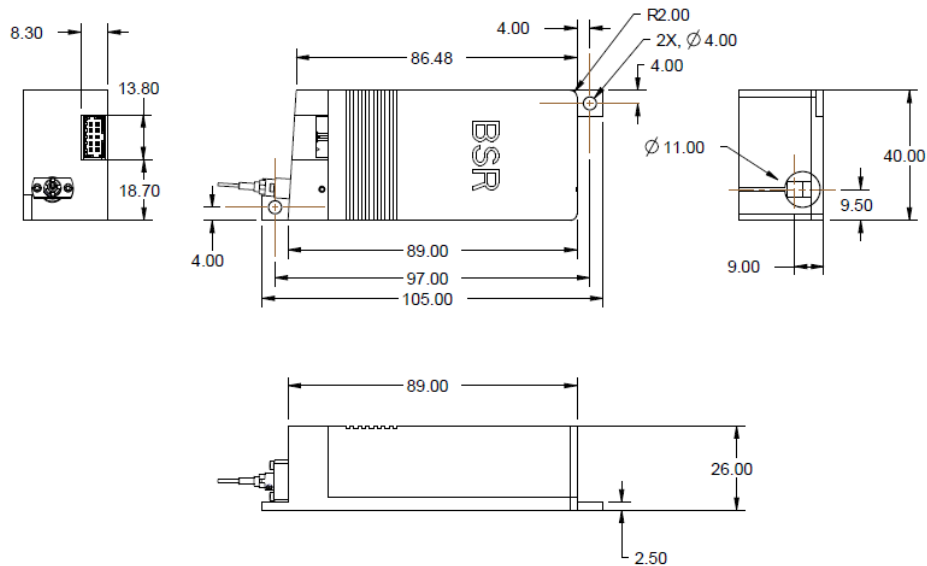

Contact Information:

Blue Sky Research * 510 Alder Drive * Milpitas, CA 95035 * (408)941-6068* Fax (408)941-0406

www.blueskyresearch.com* email: Sales@blueskyresearch.com

SpectraTec™ X Rev A 06132017

SpectraTec™ X

Polarized Multi-Laser Source

Our Sales or Applications Engineers will be happy to help you determine the best product choice to meet your requirements and provide you with detailed performance specifications on individual lasers. They can also assist you with options, system specifications or device customization your system may need.

Please contact Blue Sky Research, (408) 941- 6068, or visit our Website; www.BlueSkyResearch.com or email us at sales@blueskyresearch.com

ISO 9001:2015 Certified RoHS 3 Compliant

This component does not comply with the Federal Regulations (21 CFR Subchapter1) as administered by the Center for Devices and Radiological Health. Purchaser acknowledges that his/her products must comply with these regulations before they can be sold to a customer. The output light from laser diodes is harmful to a human body even if it is invisible, laser diodes come in a variety of wavelength and power levels and range from Class 1 to Class 4. Avoid looking at the output light of a laser directly or even indirectly through a lens during operation. Observance of operation should be through a TV camera or related equipment. Refer to IEC 60825-1, IEC 60601-2-22:2007 and 21 CFR 1040.10-1040.11 as a radiation safety standard for laser products.

Blue Sky Research follows a policy of continuous improvement. Specifications are subject to change without notice.

Contact Information:

Blue Sky Research * 510 Alder Drive * Milpitas, CA 95035 * (408)941-6068* Fax (408)941-0406

www.blueskyresearch.com* email: Sales@blueskyresearch.com

SpectraTec X Rev 06132017